

PRODUCT INFORMATION

temperature sensor -
Id.No 11118005A

DOCUMENT FOR EXTERNAL USE
Date 10.03.2025

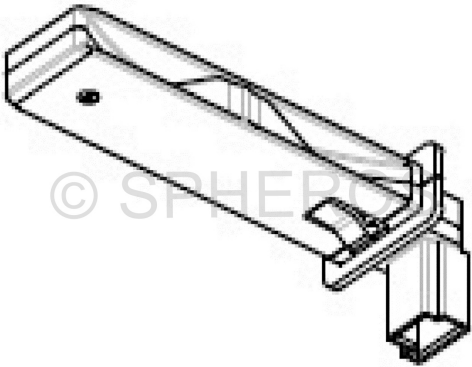

© Spheros Germany GmbH | 2024-07 | 11118005A_img_01



© Spheros Germany GmbH | 2019-09 | 11118005A_img_01



© Spheros Germany GmbH | 2019-09 | 11118005A_img_02



© Spheros Germany GmbH | 2019-09 | 11118005A_img_01

Info / Definition	circulating air
Status	€ yes mp mg md mv
Product group ID	30005
Product group	Sensors
Weight (gross)	0,005 KG
Usage/Code	NB01 Customs tariff No. 90259000 - Country of Origin: HU
ID number old	—
ID number new	—
Downloads	—